

DESIGN AND ANALYSIS OF ALLOY WHEEL RIM

V.Karthi¹, N. Ramanan², J. Justin Maria Hillary.³Assistant professor, Dept Of Mechanical Engineering , Sri Krishna college of engineering and Technology,
Coimbatore, Tamilnadu , India¹PG student, [Engineering Design] , MNM JAIN engineering college , Coimbatore, Tamilnadu , India²PG student , [Engineering Design] , Sri Krishna college of engineering and Technology , Coimbatore,
Tamilnadu , India³

ABSTRACT: The project is to design the motor cycle alloy wheel using the PRO-E and Analyzed with the ANSYS. Ansys is a tool used for the evaluation of systems and structures. It is needed to analyze complex structures, where as very simple ones. There are three processes involved which are preprocessing, analysis and visualization. The chosen material was an Aluminum alloy, magnesium alloy, titanium alloy. The aluminum alloy is better to the conventional steel wheels in strength and durability. It has excellent wear resistance, anticorrosion properties and longer service life as estimated by the stress frequency distribution. The analysis is done with the maximum load can be applied on rim. The rear wheel and front wheel have their own maximum load that can be supported. It was found that the stress of the analysis is still in the range of the yield strength of Aluminum alloy. The Displacement is at the low value. This design is still in the safe condition.

KEYWORDS: composite materials, Finite element analysis, design

I. INTRODUCTION

As technologies advanced manufacturers attempted to provide vehicles that were Faster, Stronger and lighter in construction and to do this the basic production materials needed to change. Alloy is a compound produced from aluminum magnesium or a combination of both, this brought many benefits with it to include lighter material with very little compromise in strength. A very good conductor of heat allowing for enhanced performance at the upper end of the market. An esthetically pleasing to the eye. Mass reduction allowing for better fuel consumption. Generally corrosion resistant.

II. ALLOY WHEEL

Alloy Wheels, also otherwise known as Rims, are made of alloys of aluminum magnesium. Sometimes it so happens that a mixture of both aluminum and magnesium is used in making alloy wheels. The basic advantages of using alloy wheels are that they are lighter, provide better heat conduction and also add to the looks of the Motorcycle. People using Alloys can enjoy certain advantages but that doesn't mean that spoke wheels are useless. In fact spoke wheels are still in fashion because of some of their advantages. Both types of wheels i.e. Alloy and Spoke have certain advantages. In this article, we will appraise Alloy wheels in terms of performances, durability and others.

III. ALLOY WHEEL MODEL

In modern manufacturing of metallic components, we must accept the premise that design dictates performance, and that the role of the designer is pivotal. Moreover, the designer must rely on databases and failure criteria that are robust and proven. However, as design dictates performance, performance itself is attained through alloy and process selection; both of which are quite inter connected and coupled with each other. Historically, new processes have been developed, but these have always been evaluated based on existing alloys rather than developing new alloys to take advantage of the processing attributes to optimize this coupling of alloy and process. During the last decade, we have witnessed the development of enabling tools that can be utilized to optimize alloy development,

bring in measures to better control our processes and alloys, and in brief, tools that allow intelligent alloy development for specific performance metrics and processes.

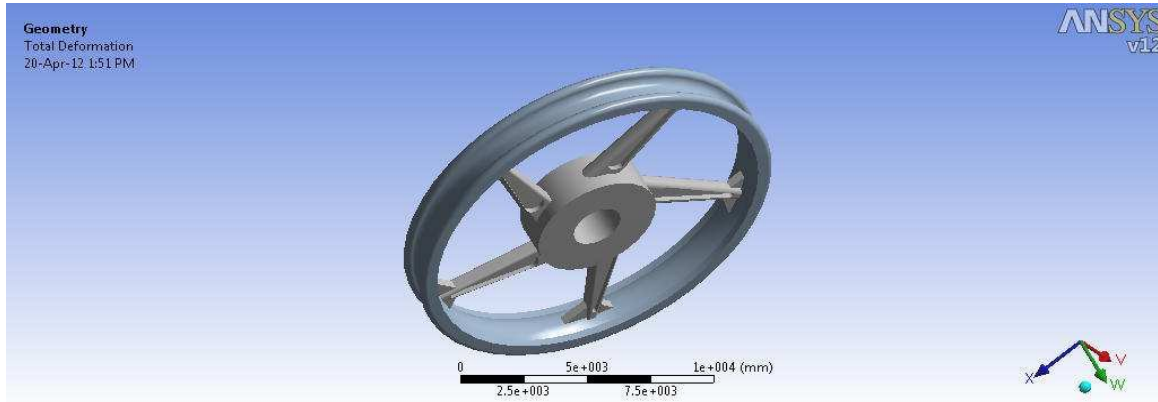

In this World Wide Report, we first review the fundamentals of Al cast alloys as a primer, followed by a discussion of the various enabling tools available to the industry – tools that were not available to the metal casting industry ten years ago or so. Specific case studies are presented and discussed to manifest the power of these enabling tools to improve and optimize alloy development. Magnesium Alloy has Key Properties like Lightweight, Low density (two thirds that of aluminum), Good high temperature mechanical properties, Good to excellent corrosion resistance.

Titanium is a low-density element (approximately 60% of the density of steel and super alloys) that can be strength need greatly by alloying and deformation processing. Titanium is nonmagnetic and has good heat-transfer properties. Its coefficient of thermal expansion is somewhat lower than that of steel and less than half that of aluminum. Titanium and its alloys have melting points higher than those of steels, but maximum useful temperatures for structural applications generally range from as low as 427°C (800°F) to the region of approximately 538°C to 595°C (1000°F to 1100°F), dependent on composition. Titanium aluminum alloys show promise for application at temperatures up to 760°C (1400°F).

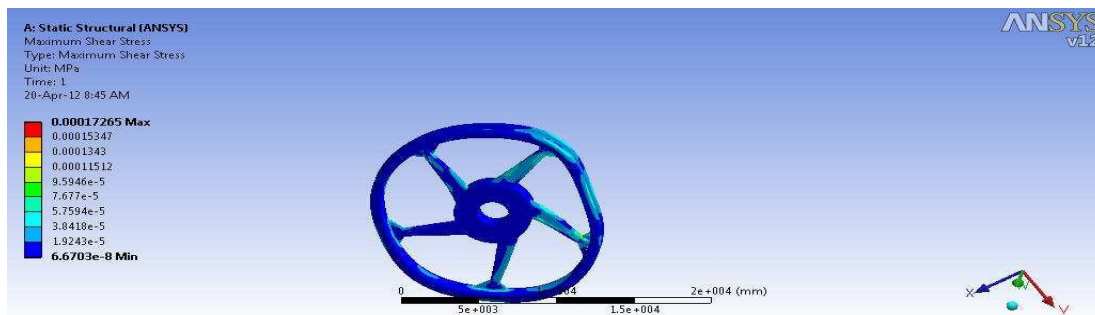

DISPLACEMENT OF ALUMINIUM ALLOY

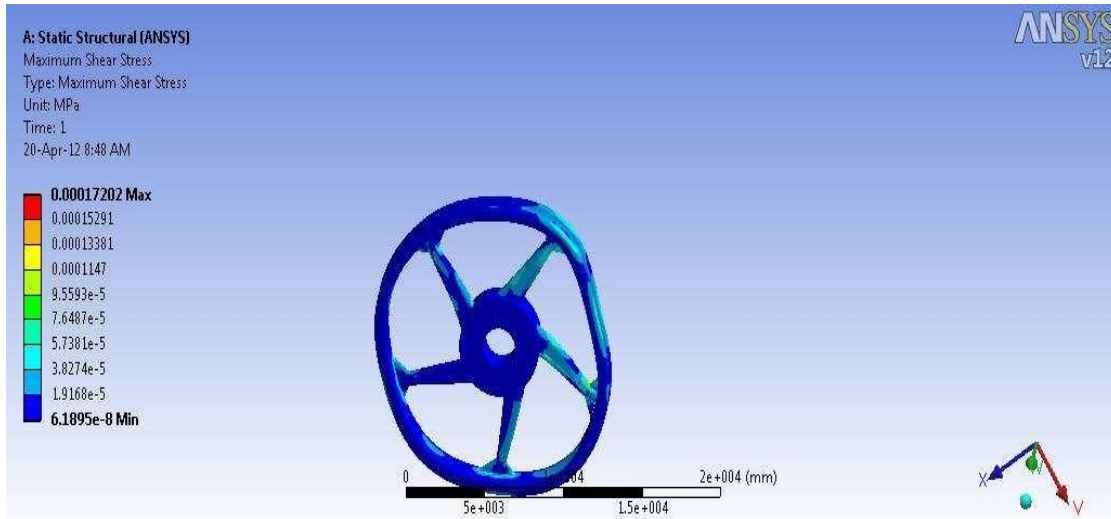

DISPLACEMENT OF MAGNESIUM ALLOY

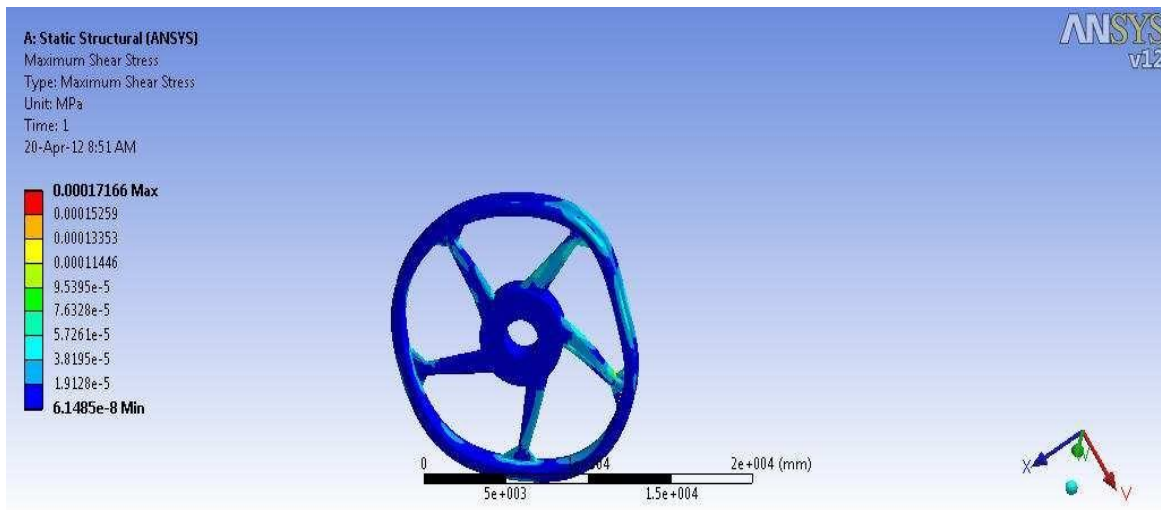

DISPLACEMENT OF TITANIUM ALLOY

IV. SHEAR STRESS

When equal and opposite forces act tangentially on any cross-sectional plane of the body, tending to slide one part of the body over the other part then the body is said to be in state of shear.

$$F_s = \text{total tangential force/area of cross-section of the resisting section} \quad [F_s = P/A]$$

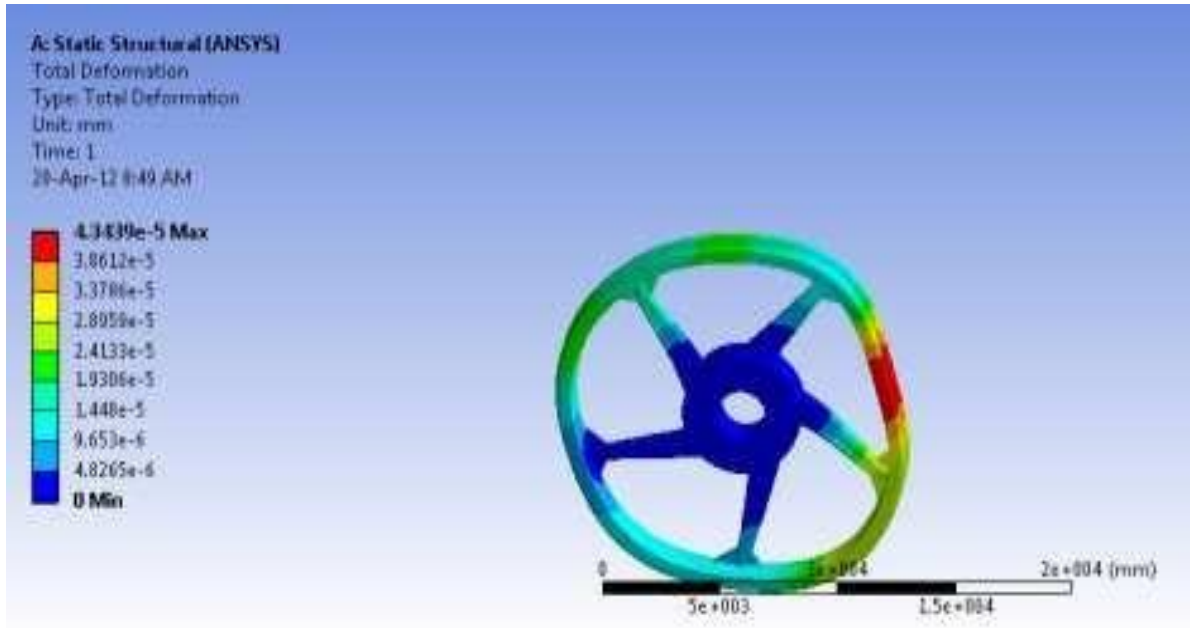

STRESS OF ALUMINIUM ALLOY

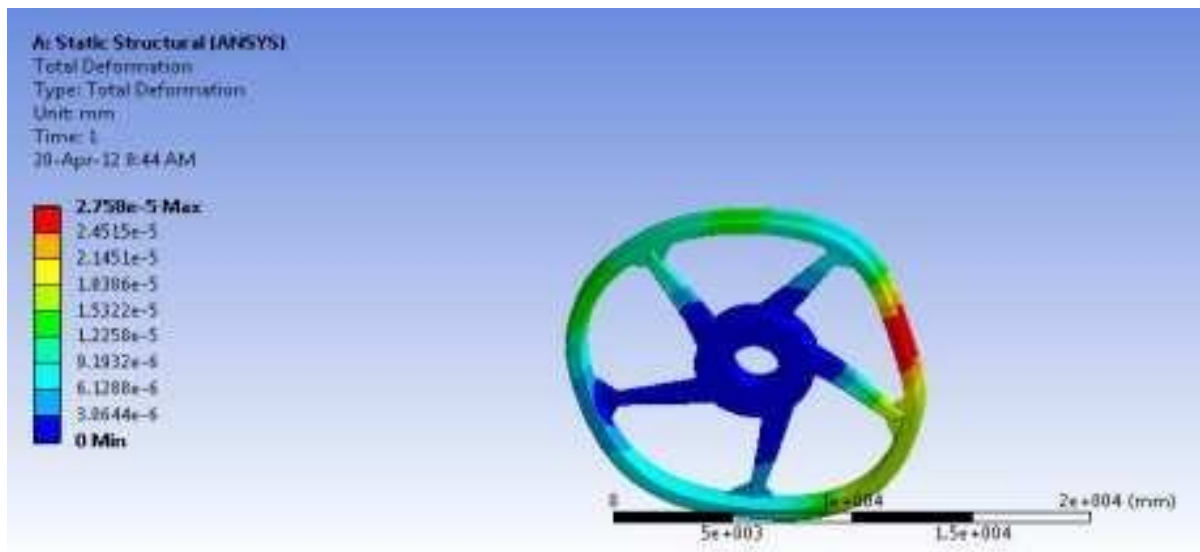

STRESS OF MAGNISUM ALLOY

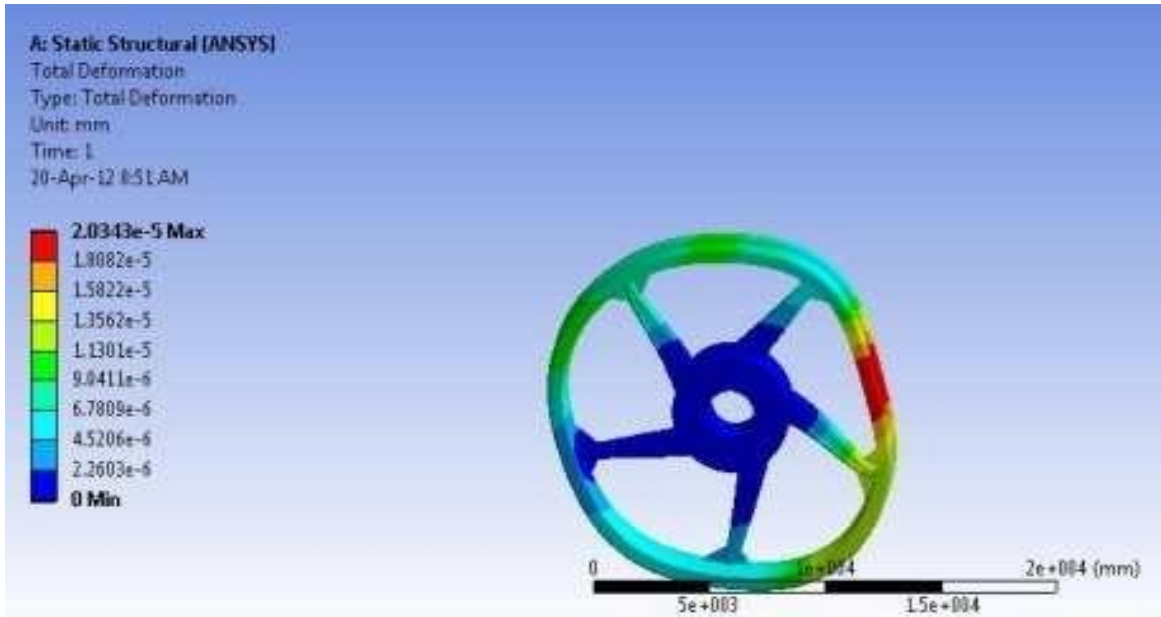

STRESS OF TITANIUM ALLOY

V.RESULT AND DISCUSSION

The above material result for displacement as titanium displacement are 0.000171 mm and aluminium alloy displacement has 0.000173 mm and magnesium alloy are 0.000175 mm. and the stress of aluminium alloy are 0.0005 N/mm and titanium alloy 0.0002 N/mm and magnesium alloy are 0.0003 N/mm. And the compare to the material of titanium, aluminium and magnesium are the titanium material has less weight and low corrosion resistance high thermal conductivity and better fatigue properties. The conclusion of the project compare to the three material titanium has best one of the material. So we are preferred titanium material. And also the comparing process is stresses and deformation for above materials. The best one is titanium alloy to compare with aluminum and magnesium alloy 'But the cost of the titanium alloy is high. It should corrosion resistance and also the life is more.

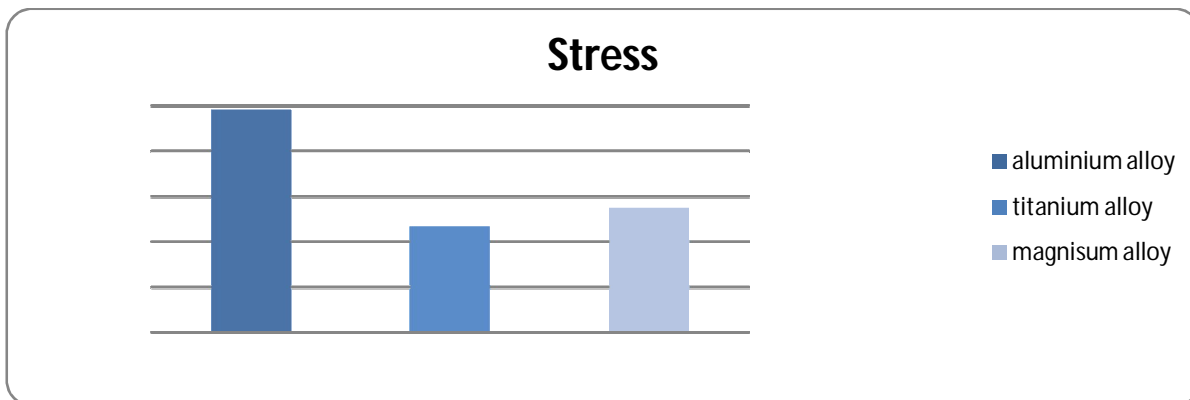

STRESS OF DIFFERENT MATERIAL

International Journal of Innovative Research in Science, Engineering and Technology

An ISO 3297: 2007 Certified Organization

Volume 3, Special Issue 2, April 2014

Second National Conference on Trends in Automotive Parts Systems and Applications (TAPSA-2014)

On 21st & 22nd March, Organized by

Sri Krishna College of Engineering & Technology, Kuniamuthur, Coimbatore-641008, Tamilnadu, India

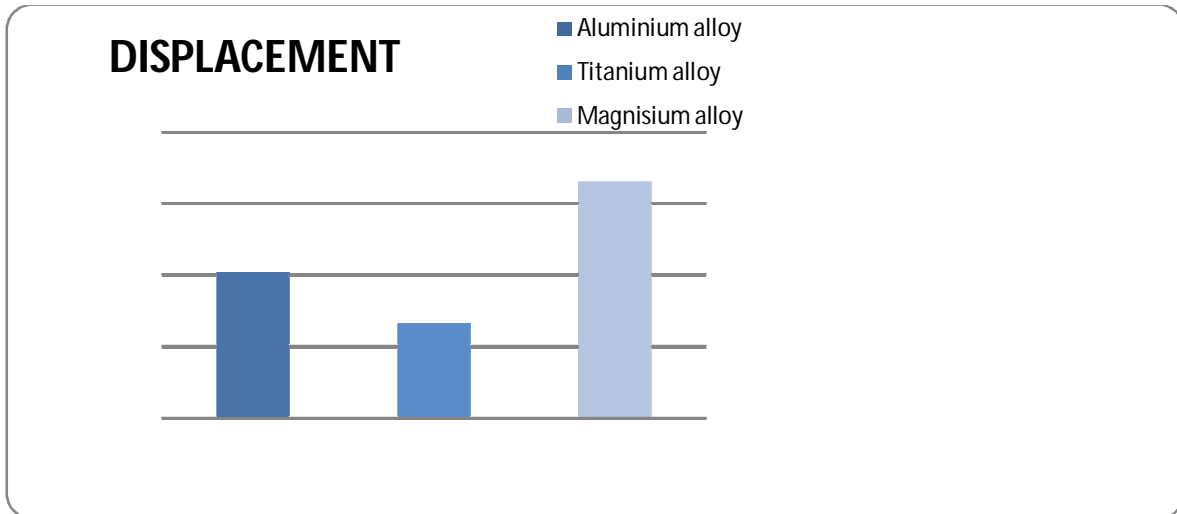

Displacement of different Material

REFERENCES

- [1] Adelbert Philo Mills, (1922), Materials of Construction: Their Manufacture and Properties, John Wiley & sons, inc, originally published by the University of Wisconsin, Madison
- [2] Hogan, (1969), "Density of States of an Insulating Ferro magnetic Alloy".
- [3] Zhang, X.; Suhl, H. (1985), "Spin- wave-related period doublings and chaos under transverse pumping " Michael Baucio (2005)
- [4] ASM metals reference book, ASM International Jon L. Dossett, Howard E. Boyer (2006) Practical heat treating
- [5] T. A. Rickard (1941), "The Use of Meteoric Iron ". The Journal of the Royal Anthropological Institute of Great Britain and Ireland