

Child Safety Wearable Device

Akash Moodbidri

Department of Electrical and Computer Engineering
San Francisco State University
CA 94132
Email: amoodbid@mail.sfsu.edu

Hamid Shahnasser

Department of Electrical and Computer Engineering
San Francisco State University
CA 94132
Email: hamid@sfsu.edu

Abstract— This paper discusses the concept of a smart wearable device for little children. The major advantage of this wearable over other wearable is that it can be used in any cellphone and doesn't necessarily require an expensive smartphone and not a very tech savvy individual to operate. The purpose of this device is to help parents locate their children with ease. At the moment there are many wearables in the market which help track the daily activity of children and also help find the child using Wi-Fi and Bluetooth services present on the device. But Wi-Fi and Bluetooth appear to be an unreliable medium of communication between the parent and child. Therefore, the focus of this paper is to have an SMS text enabled communication medium between the child's wearable and the parent as the environment for GSM mobile communication is almost present everywhere. The parent can send a text with specific keywords such as "LOCATION" "TEMPERATURE" "UV" "SOS" "BUZZ", etc., the wearable device will reply back with a text containing the real time accurate location of the child which upon tapping will provide directions to the child's location on google maps app and will also provide the surrounding temperature, UV radiation index so that the parents can keep track if the temperature or UV radiation is not suitable for the child. The prime motivation behind this paper is that we know how important technology is in our lives but it can sometimes can't be trusted, and we always need to have a secondary measure at hand. The secondary measure used in this project is the people present in the surrounding of the child who could instantly react for the child's safety till the parents arrive or they could contact the parents and help locate them. The secondary measure implemented was using a bright SOS Light and distress alarm buzzer present on the wearable device which when activated by the parents via SMS text should display the SOS signal brightly and sound an alarm which a bystander can easily spot as a sign of distress. Hence this paper aims at providing parents with a sense of security for their child in today's time.

Keywords—IoT, Children, Arduino, Safety, Wearable.

I. INTRODUCTION

The Internet of Things System (IoT) [1] refers to the set of devices and systems that stay interconnected with real-world sensors and actuators to the Internet. IoT includes many different systems like smart cars, wearable devices [2] and even human implanted devices, home automation systems [3] and lighting controls; smartphones which are increasingly being used to measure the world around them. Similarly, wireless sensor networks [4] that measure weather, flood defenses, tides and more. There are two key aspects to the IoT: the devices themselves and the server-side architecture that supports them

[5]. The motivation for this wearable comes from the increasing need for safety for little children in current times as there could be scenarios of the child getting lost in the major crowded areas. This paper focusses on the key aspect that lost child can be helped by the people around the child and can play a significant role in the child's safety until reunited with the parents. Most of the wearables available today are focused on providing the location, activity, etc. of the child to the parents via Wi-Fi [8] and Bluetooth [9]. But Wi-Fi and Bluetooth seem a very unreliable source to transfer information. Therefore it is intended to use SMS as the mode of communication between the parent and child's wearable device, as this has fewer chances of failing compared to Wi-Fi and Bluetooth. The platform on which this project will be running on is the Arduino [10] Uno microcontroller board based on the ATmega328P, and the functions of sending and receiving SMS, calls and connecting to the internet which is provided by the Arduino GSM shield using the GSM network [11]. Also, additional modules employed which will provide the current location of the child to the parents via SMS. The second measure added is SOS Light indicator that will be programmed with Arduino UNO board to display the SOS signal using Morse code. The different modules stay enclosed in a custom designed 3D printed case [12]. In the scenario, a lost child can be located by the parent could send an SMS to the wearable device which would activate the SOS light feature on the wearable. Therefore alerting the people around the child that the child is in some distress and needs assistance as the SOS signal is universally known as the signal for help needed. Additionally, the wearable comes equipped with a distress alarm buzzer which sets to active by sending the SMS keyword "BUZZ" to the wearable. Hence the buzzer is loud and can be heard by the parent from very considerable distance. Also the parents via SMS can receive accurate coordinates of the child, which can help them locate the child with pinpoint accuracy. Some of the existing work done on these similar lines are for example the low-cost, lightweight Wristband Vital [2] which senses and reports hazardous surroundings for people who need immediate assistance such as children and seniors. It is based on a multi-sensor Arduino micro-system and a low-power Bluetooth 4.1 module. The Vital band samples data from multiple sensors and reports to a base station, such as the guardian's phone or the emergency services. It has an estimated battery life of 100 hours. The major drawback for the Vital band is that it uses Bluetooth as the mode of communication between child and the parent. Since the distance between the two in some cases could be substantial and the Bluetooth just won't be able to establish a close link between the two. Some more of the similar wearable devices are the Mimo, Sproutling, and

iSwingband having their several drawbacks. Therefore, the wearable device proposed will be communicating with the parent via SMS which would ensure that there is a secure communication link. Also, customization of the wearable is possible as per our needs by reprogramming the Arduino system.

II. SYSTEM DESIGN AND ARCHITECTURE

This section discusses the architecture and the design methodologies chosen for the development of the Child Safety wearable device.

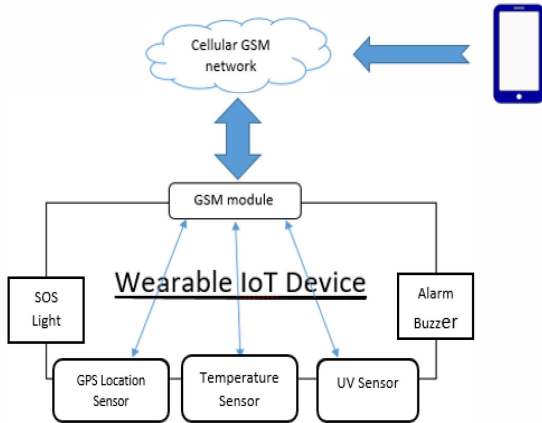

Fig 1. System overview of the wearable device.

A. System Overview

An ATmega328p microcontroller controls the system architecture of the wearable with an Arduino Uno boot-loader. A 5 pin header allows for power (+3V) and ground connections as well as providing access to TX, RX, and reset pins of the ATmega328p. The Fig illustrates the architecture of the child safety wearable device, which depicts the various technologies and technological standards used. The system architecture of the wearable is based and controlled by an ATmega328p microcontroller with an Arduino Uno bootloader. The Arduino Uno collects various types of data from the different modules interfaced to it, such as the GPS module upon being triggered by the Arduino GSM shield. The GSM shield is used as an interface to send the data received by the Arduino Uno via SMS or MMS to a smartphone over GSM/GPRS. The GSM shield functions as a trigger for the Arduino Uno to request data from its various modules. If an SMS text with distinct characters is sent to request the current location or GPS coordinates is sent to the Arduino GSM shield via the user's smartphone, then the GSM shield triggers the Arduino Uno to request the current GPS coordinates. The GSM shield uses digital pins 2 and 3 for the software serial communication with the M10. Pin2 is connected to the M10's TX pin and pin 3 to its RX pin. The M10 is a Quad-band GSM/GPRS modem that works at GSM850MHz, GSM900MHz, DCS1800MHz, and PCS1900MHz. It also supports TCP/UDP and HTTP protocols through a GPRS connection. Once the Arduino Uno has received at the coordinate information, it will process this information and transfer it over to the GSM shield, which then via SMS sends

the coordinates to the user's smartphone. The user can just tap on the coordinates which will open up the default GPS application installed on the phone and will show the user the distance between the child and the user.

B. Wearable IoT Device

The wearable device, for now, is not built on a SoC model, rather has been proposed using larger components and can later build on the SoC platform once put into manufacture. The wearable IoT device tasked with acquiring various data from the all the different modules connected. It comprises of Arduino Uno based on the ATmega328P microcontroller. It receives the data from its various physically connected modules, anatomizes this data and refines the data in a more user understandable format to the different available user interfaces. The user, therefore, can conveniently view the information on their cellphone. The physical characteristics of the wearable device are proposed to be as a wrist watch which remains placed around the wrist of the child during times when the child is not being accompanied by an adult/parent. For the moment the design is not made compact, since the main focus now has been to show that this concept of smart wearables would be highly impactful for the safety of children. The wearable system runs on a battery with an output voltage of 5V. In order to maximize power consumption, the wearable device has been programmed to provide GPS and image information only upon request by SMS text via GSM shield.

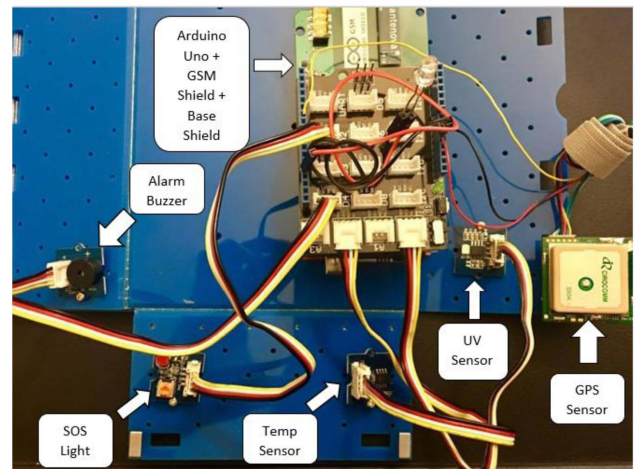

Fig 2. Proposed wearable IoT Device.

1) GPS Location Sensor

For determining the real time location of the child Parallax PMB-648 GPS module has been used which communicates with the Arduino Uno through a 4800 bps TTL-level interface. The connections between the Arduino Uno and the GPS module established with three wired connections which enable the Arduino to read the GPS data. The GPS module receives location information from the various satellites present in the

NAVSTAR (American Satellites Timing and Ranging Global Positioning System) GPS system [1]. It has a low power consumption and size of the only 32x32mm, which is very compact. 20 parallel satellite-tracking channels for fast acquisition and reacquisition. The output received from the GPS module is a standard string information which is governed by the National Marine Electronics Association (NMEA) protocol. To interface the PMB-648 GPS module with the Arduino to provide precise latitude and longitude GPS coordinates, the TinyGPS library was added into the Arduino IDE. The Vin (red wire) on the PMB-648 GPS module is connected to the 5V pin on the Arduino Uno via jumper cables. Similarly, the GND (black wire) pin on the GPS module is connected to the GND pin on the Arduino Uno via jumper cables. The TXD (yellow wire) is connected to pin 6 of the Arduino Uno via jumper cables on the breadboard. The pin six on the Arduino Uno is a digital pin which can also be used for PWM (Pulse Width Modulation) applications. Once the SMS trigger text "LOCATION" is sent from the cell phone of the user, this text is received by the Arduino GSM Shield which in turn triggers the Arduino Uno to execute the GPS code to fetch the current, accurate location of the GPS module. The location output received from the GPS module is in the following format:

- | | |
|-------------------------------|--------------------------------|
| 1) 220516-Time Stamp | 2) A-validity- A-ok, V-invalid |
| 3) 5133.82-current Latitude | 4) N-North/South |
| 5) 00042.24-current Longitude | 6) W-East/West |
| 7) 173.8-Speed in knots | 8) 231.8-True course |
| 9) 130694-Date Stamp | 10) 004.2-Variation |
| 11) W-East/West | 12) *70-checksum |

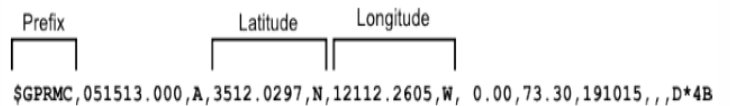

Then the final results for latitude and longitude are inserted into the following URL format:

```
http://maps.google.com/?q=<lat>, <lng>
```

For example:

Reading received: 37.7163, -122.4739

SMS sent to the user's smartphone:
<http://maps.google.com/?q=37.7163,-122.4739>

Hence the user can just directly click on this received Google maps hyperlink which will automatically redirect the user to the Google Maps app on the smartphone and show the pinpoint location of the child. This SMS can be received directly on the default SMS app or via Android app on the user's smartphone.

2) Temperature Sensor

In order to measure the temperature of the surroundings of the child, a seed studio grove temperature sensor was used. The sensor module is equipped with a thermistor for measuring the ambient temperature and the fluctuations with high accuracy. The observable temperature detectability for this sensor ranges from -40°C to -125°C and the precise accuracy for this device range from +1.5°C to -1.5°C. The temperature is connected to the Arduino Uno and GSM shield using a Grove base shield which contains eight digital ports ranging from D1 to D8, four analog ports ranging from A0 to A3 and 4 I2C ports. Therefore, the temperature sensor is connected to the A2 analog port of the base shield. The temperature value is stored in a string getTemp(a), where "a" is the integer type. Hence the getTemp(a) is called by the GSM module upon receiving the proper SMS keyword "TEMPERATURE" by the user's smartphone.

3) UV Sensor

In order to measure the ultraviolet radiation intensity present around the surroundings of the child, a seed studio grove UV sensor was used. The UV sensor is built on the GUVA-S12D sensor (spectral range of 200nm-400nm). The sensor works by outputting electrical signal which alters with UV intensity. It is a highly sensitive sensor. It is known that the absorption of UV rays in minor amounts can be progressive to the health of a person as it helps in the production of Vitamin D The purpose of a UV sensor in a child wearable device can be to protect the child from harmful radiations of the sun. The UV sensor is

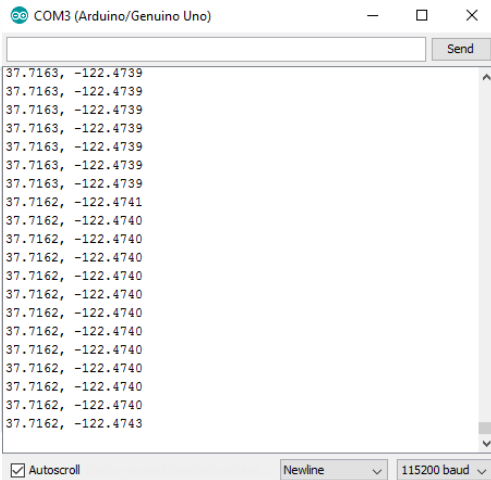

Fig 3. Output received GPS location sensor.

The latitude and longitude coordinates received are stored in variables called "flat" and "flon," which are then called upon when the SMS text received on the GSM module matches with the keyword "LOCATION." If an SMS text is received which contains none of the pre-programmed keywords, then the Arduino GSM shield automatically deletes the text message and does not reply back the user the with any location details.

Once the SMS trigger text "LOCATION" is sent from the smartphone of the user, this text is received by the Arduino GSM Shield which in turn triggers the Arduino Uno to execute the GPS code to fetch the current, accurate location of the GPS module. The location output string received from the GPS module is in the following format:

connected to the A0 port of the base shield. In the figure below shown is the output received from the UV sensor for the different intensities of sunlight.

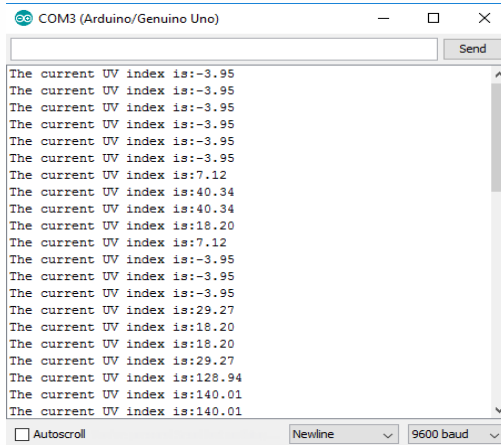

Fig 4. Output received from UV sensor.

4) SOS Light

The another theory that this paper focusses on is that bystanders are the first mode of help for a missing child. The purpose of the SOS light is to be able to alert the people nearby that the child might be in distress since the light will be flashing the universal SOS light symbol which many people nowadays know for to be a sign for help. This can be activated by the parent itself by sending an SMS text with the keyword “SOS” to the child’s wearable which will activate the SOS light flashing. The SOS light works on the principal of Morse code in which "S" stands for three short dots and the "O" stands for three long dashes. Since a very long time, the SOS signal has been universally known for being the sign of distress and help. The SOS signal is referred to by all security personals, who if find the child to be missing can act and help locate the parents with surplus resources present at their disposal. The SOS Light is connected to the pin 13 of the base shield.

5) Distress Alarm Buzzer

In the scenario, if a child is separated from his/her parents. The parent can locate their child by sounding a very loud alarm on the wearable. To achieve this, grove seed studio buzzer was used, which has a piezoelectric module which is responsible for emitting a strong tone upon the output being set to HIGH. The grove buzzer module is activated upon sending an SMS text with the keyword "BUZZ" from a cell phone. Also, this buzzer works similar to the SOS led by alerting the people nearby with the distressed tone that the child might be lost and is in need of assistance. The buzzer is connected to the D4 digital port of the base shield.

C. Gateway:

1) Arduino GSM Shield

It transfers the information over to the user via SMS by using General Packet Radio Service (GPRS) which can provide data rates around 56-114 Kbit/sec. Arduino provides various libraries such as Ethernet, Wi-Fi for the different Arduino shields. Similarly, Arduino provides GSM libraries for their official GSM shield as well which allows the GSM shield to make/receive a call, send/receive SMS and act as a client/server. The Arduino GSM shield receives 5V power supply directly from the 5V pin connection at the Arduino Uno 5V. The serial communication between the Arduino Uno and Arduino gsm shield is performed between the software serial digital pins 2,3 and also reset pins 7. The GSM shield has been programmed to receive SMS text messages from the parent's cellphone. The GSM shield will constantly be scanning the received text messages for the specific keywords such as "LOCATION" "TEMPERATURE" "UV" "BUZZ" "SOS". If the text message received does not contain any of the pre-programmed keywords, then the GSM shield had programmed to delete the text message completely and reply back nothing to the sender. Since the GSM shield is an Arduino produced device, it has the necessary GSM libraries installed into the Arduino IDE which makes the interfacing with Arduino Uno much more reliable. The primary reason for using the GSM shield as the mode of communication over Wi-Fi and Bluetooth was that this wearable was aimed at being accessible to any cellphone user and not necessarily an expensive smartphone user. Also, to make the technology as user-friendly as possible, so that a user who is technologically challenged can also use it with ease.



Fig 5. Gateway: Arduino GSM Shield.

2) Cellphone SMS app interface

An Arduino GSM Shield is used as it transfers the information over to the user via SMS by using General Packet Radio Service (GPRS) which can provide data rates around 56-114 Kbit/sec. Arduino provides various libraries such as Ethernet, Wi-Fi for the different Arduino shields. Similarly, they provide GSM libraries for their official GSM shield as well which allows the gsm shield to make/receive a call, send/receive SMS and act as a client/server.

III. RESULTS:

In this section, the experimental tests were performed to determine the various components of the proposed wearable device.

A. GPS Location Sensor

Upon testing the wearable device multiple times with repeated SMS texts. The GPS location sensor was able to respond back with precise latitude and longitude coordinates of the wearable device to the user's cellphone, which then the user would click on the received Google maps URL which would, in turn, open the google maps app and display the pinpoint location. In all the scenarios the GPS module was tested, it would respond back to the user's cellphone within a minute. The GPS turned out to be so precise with the location that it performed even better than the GPS on an expensive smartphone. As shown in the image below, the GPS module (red bubble) was able to show the current location of the wearable with pinpoint accuracy and also show exactly at which side of the building it is present. Whereas for the smartphone (blue dot) is showing the wearable to be present on the street, which is marginally off from the exact location. This marginal miss match in the pinpoint location of the wearable can turn out to be fatal in a real life scenario, where the parent may be miss lead to the wrong location of the child. Therefore, the Parallax PMB-648 GPS module proves to be successful in providing the precise location with high accuracy and with a good response time. The only drawback that could be stated was, the GSM module could not interpret multiple valid keywords sent in a single message. For example, SMS string sent: LOCATION TEMPERATURE UV BUZZ SOS; it would not send a reply back to the gsm module.

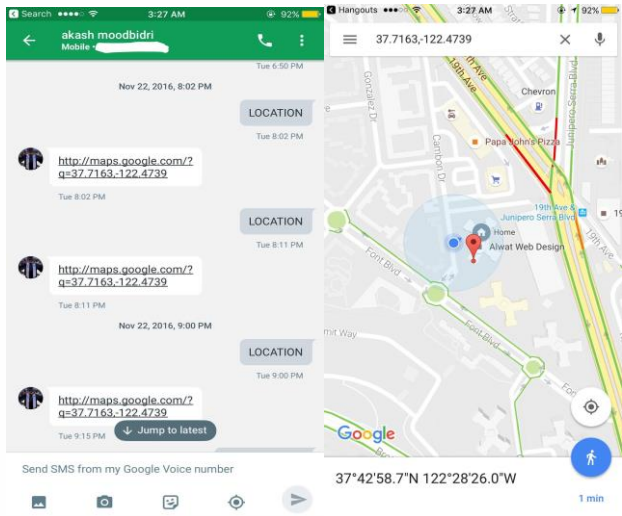

Fig 6. Left: Cellphone SMS app for LOCATION sensor and Right: Google maps with latitude and longitude coordinates displayed.

B. Temperature and UV sensor:

Similar to the GPS location sensor, the Temperature, and UV sensors were tested multiple times under different temperatures and higher intensities of sunlight. Both the sensors performed exceptionally well to the test performed. The response time to

receive a response back to the keywords "TEMPERATURE" and "UV" was under a minute. Also, the temperature sensor was subjected to higher temperatures and compared with a thermostat reading present in the room which would differ with the sensor reading by +0.2°C to -0.2°C. Also, the UV sensor was measured under different intensities of sunlight. The UV sensor was quick in responding to the changes in the intensity of sunlight. The response time to receive a response back to the keywords "UV" was under a minute as well.

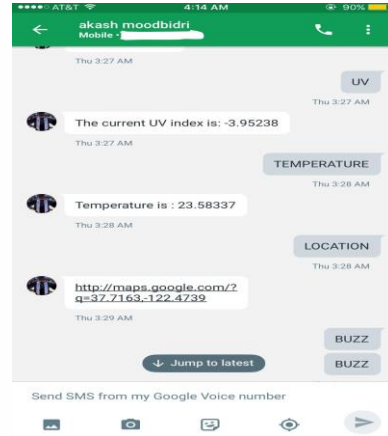

Fig 7. SMS app screen for UV and Temperature sensor

C. SOS Light and Distress Alarm Buzzer:

The light and buzzer differ from the above sensors in the SMS trigger mechanism. Upon sending an SMS with either "SOS" or "BUZZ," this would trigger the light and buzzer to perform an output function instead of providing measurements back to the user's cellphone such as in the scenario of the other sensors. Upon receiving the correct keywords, the SOS light and Alarm Buzzer would first perform the particular task of flashing the SOS light and sounding a distress alarm which can take a little longer than their sensor counterparts. After completion of their respective functions, the response is sent back to the user' cell phone stating: "SOS Signal Sent" and "Playing Buzzer."

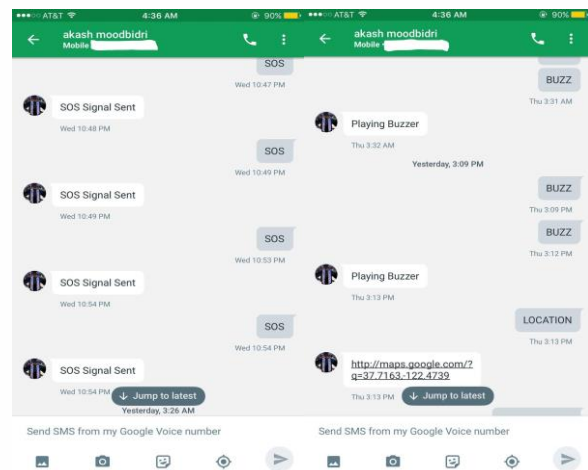

Fig 8. SMS app screen for Left: SOS Light and Right: Distress alarm buzzer.

1) *Camera Module:*

For surveillance of the child's surroundings, to get a clearer picture of the location, this wearable can also contain a camera module incorporated in it. The hardware that could be used would be a adafruit TTL serial camera. Since the major focus of this wearable project is the GSM module which is a better alternative than Bluetooth, Wi-Fi or ZigBee due to the short range and connectivity issues of these technologies. Therefore, for this project using the GSM technologies is beneficial as the cellular range is vast and since all the communication between the wearable and the user is taking place via SMS, therefore no internet connectivity is required at all. But, still, the Arduino GSM shield possess the added advantage of using GPRS which enables the board to use the internet if required. Whereas for the camera module which supports video streaming but due to the constraint of trying to use only sms, therefore only four wire connections will be taking place. The red and black wires will be connected directly to +5V and GND respectively to the Arduino uno board. Whereas for the RX pin which will be used for sending data via arduino uno and arduino gsm board and for the TX pin which will be utilized for receiving incoming data via from the modules. The 10K resistor divider, the camera's serial data pins are 3.3v logic, and it would be a good idea to divide the 5V down so that its 2.5V. Normally the output from the digital 0 pin is 5V high, the way we connected the resistors is so the camera input (white wire) never goes above 3.3V. To talk to the camera, the Arduino uno will be using two digital pins and a software serial port to talk to the camera. Since the camera or the Arduino Uno do not have enough onboard memory to save snapshots clicked and store it temporarily, therefore an external storage source microSD breakout board will be used to save the images temporarily. The camera works on a standard baud rate of 38400 baud. The camera will be collecting information in the same manner as the GPS module. It will be on standby conserving power waiting for the particular keyword "SNAPSHOT" to be sent from the user's smartphone to the GSM shield will activate the camera to start clicking a snapshot of the surrounding and save the file temporarily on the external microSD card. After which Arduino Uno will access the saved image from the microSD storage and transfer it to the GSM module which send it to the user via SMS/MMS text.

2) *Android App:*

The idea behind the Android app has been derived from having an automated bot to respond to text message responses from the user. It will provide the user with predefined response options at just the click of a button. The user doesn't need to memorize the specific keywords to send. Also, the bot will be preprogrammed to present the user with a set of predefined keyword options such as "LOCATION," "SNAPSHOT," "SOS," etc. Whereas for the future aspect of this wearable device based on what type sensor is added to it, additional specific keywords could be added such as, "HUMIDITY," "ALTITUDE," etc.

The child safety wearable device is capable of acting as a smart IoT device. It provides parents with the real-time location, surrounding temperature, UV radiation index and SOS light along with Distress alarm buzzer for their child's surroundings and the ability to locate their child or alert bystanders in acting to rescue or comfort the child. The smart child safety wearable can be enhanced much more in the future by using highly compact Arduino modules such as the LilyPad Arduino which can be sewed into fabrics. Also a more power efficient model will have to be created which will be capable of holding the battery for a longer time.

REFERENCES

- [1] B. Dorsemaine, J. P. Gaulier, J. P. Wary, N. Kheir and P. Urien, "Internet of Things: A Definition and Taxonomy," Next Generation Mobile Applications, Services and Technologies, 2015 9th International Conference on, Cambridge, 2015, pp. 72-77.
- [2] H. Moustafa, H. Kenn, K. Sayrafian, W. Scanlon and Y. Zhang, "Mobile wearable communications [Guest Editorial]," in IEEE Wireless Communications, vol. 22, no. 1, pp. 10-11, February 2015.
- [3] S. Nasrin and P. J. Radcliffe, "Novel protocol enables DIY home automation," Telecommunication Networks and Applications Conference (ATNAC), 2014 Australasian, Southbank, VIC, 2014, pp. 212-216.
- [4] F. A. Silva, "Industrial Wireless Sensor Networks: Applications, Protocols, and Standards [Book News]," in IEEE Industrial Electronics Magazine, vol. 8, no. 4, pp. 67-68, Dec. 2014.
- [5] Jun Zheng; Simplot-Ryl, D.; Bisdikian, C.; Mouftah, H.T., "The internet of things [Guest Editorial]," in Communications Magazine, IEEE, vol.49, no.11, pp.30-31, November 2011 doi: 10.1109/MCOM.2011.6069706
- [6] K. Braam, Tsung-Ching Huang, Chin-Hui Chen, E. Montgomery, S. Vo and R. Beausoleil, "Wristband Vital: A wearable multi-sensor microsystem for real-time assistance via low-power Bluetooth link," Internet of Things (WF-IoT), 2015 IEEE 2nd World Forum on, Milan, 2015, pp. 87-91. doi: 10.1109/WF-IoT.2015.7389032
- [7] "Digital parenting: The best wearables and new smart baby monitors. The latest smart baby monitors and connected tech for your peace of mind," Tech. Rep., 2015. [Online]. Available: <http://www.wearable.com/parenting/the-best-wearables-babies-smart-baby-monitors>.
- [8] "WiFi and WiMAX - break through in wireless access technologies," Wireless, Mobile and Multimedia Networks, 2008. IET International Conference on, Beijing, 2008, pp. 141-145.
- [9] P. Bhagwat, "Bluetooth: technology for short-range wireless apps," in IEEE Internet Computing, vol. 5, no. 3, pp. 96-103, May/Jun 2001.

- [10] Y. A. Badamasi, "The working principle of an Arduino," Electronics, Computer and Computation (ICECCO), 2014 11th International Conference on, Abuja, 2014, pp. 1-4.
- [11] N. N. Prince, "Design and implementation of microcontroller based short message service control system," Internet Technology and Secured Transactions (ICITST), 2013 8th International Conference for, London, 2013, pp. 494-499.
- [12] A. Anastasiou, C. Tsirmpas, A. Rompas, K. Giokas and D. Koutsouris, "3D printing: Basic concepts mathematics and technologies," Bioinformatics and Bioengineering (BIBE), 2013 IEEE 13th International Conference on, Chania, 2013, pp. 1-4.